

MPXV7002 Integrated Silicon Pressure Sensor On-Chip Signal Conditioned, Temperature Compensated and Calibrated

The MPXV7002 series piezoresistive transducers are state-of-the-art monolithic silicon pressure sensors designed for a wide range of applications, but particularly those employing a microcontroller or microprocessor with A/D inputs. This transducer combines advanced micromachining techniques, thin-film metallization, and bipolar processing to provide an accurate, high level analog output signal that is proportional to the applied pressure.

Features

- 2.5% Typical Error over +10°C to +60°C with Auto Zero
- 6.25% Maximum Error over +10°C to +60°C without Auto Zero
- Ideally Suited for Microprocessor or Microcontroller-Based Systems
- Thermoplastic (PPS) Surface Mount Package
- Temperature Compensated over +10° to +60°C
- Patented Silicon Shear Stress Strain Gauge
- Available in Differential and Gauge Configurations

MPXV7002

-2 to +2 kPa (-0.3 to +0.3 psi)
0.5 to 4.5 V Output

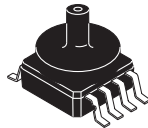

MPXV7002GC6U/C6T1
CASE 482A

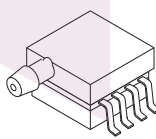

MPXV7002GP
CASE 1369

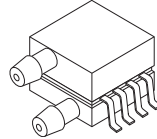

MPXV7002DP
CASE 1351

Small Outline Package

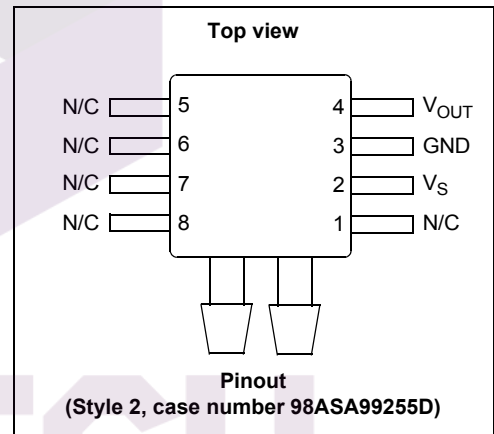

ORDERING INFORMATION									
Device Name	Package Options	Case No.	# of Ports			Pressure Type			Device Marking
			None	Single	Dual	Gauge	Differential	Absolute	
Small Outline Package (MPXV7002 Series)									
MPXV7002GC6U	Rails	482A		•		•			MPXV7002G
MPXV7002GC6T1	Tape & Reel	482A		•		•			MPXV7002G
MPXV7002GP	Trays	1369		•		•			MPXV7002G
MPXV7002DP	Trays	1351			•		•		MPXV7002DP
MPXV7002DPT1	Tape & Reel	1351			•		•		MPXV7002DP

Contents

1	Operating Characteristics	3
2	Maximum Ratings	4
3	On-Chip Temperature Compensation, Calibration and Signal Conditioning	5
4	Pressure (P1)/Vacuum (P2) Side Identification Table	6
5	Minimum Recommended Footprint for Surface Mounted Applications	6
6	Package Dimensions	7
7	Revision History	12



Related Documentation

The MPXV7002 device features and operations are described in a variety of reference manuals, user guides, and application notes. To find the most-current versions of these documents:

1. Go to the MPXV7002 web page at <http://www.nxp.com/products/:MPXV7002>.
2. Click the Documentation tab.

MPXV7002

1 Operating Characteristics

Table 1. Operating Characteristics ($V_S = 5.0$ Vdc, $T_A = 25^\circ\text{C}$ unless otherwise noted. Decoupling circuit shown in [Figure 3](#) required to meet specification.)

Characteristic	Symbol	Min	Typ	Max	Unit
Pressure Range ⁽¹⁾	P_{OP}	-2.0	—	2.0	kPa
Supply Voltage ⁽²⁾	V_S	4.75	5.0	5.25	Vdc
Supply Current	I_o	—	—	10	mAdc
Pressure Offset ⁽³⁾ @ $V_S = 5.0$ Volts	V_{off}	0.25	0.5	0.75	Vdc
Full Scale Output ⁽⁴⁾ @ $V_S = 5.0$ Volts	V_{FSO}	4.25	4.5	4.75	Vdc
Full Scale Span ⁽⁵⁾ @ $V_S = 5.0$ Volts	V_{FSS}	3.5	4.0	4.5 V	Vdc
Accuracy ⁽⁶⁾	—	—	$\pm 2.5^{(7)}$	± 6.25	% V_{FSS}
Sensitivity	V/P	—	1.0	—	V/kPa
Response Time ⁽⁸⁾	t_R	—	1.0	—	ms
Output Source Current at Full Scale Output	I_{O+}	—	0.1	—	mAdc
Warm-Up Time ⁽⁹⁾	—	—	20	—	ms

1. 1.0 kPa (kiloPascal) equals 0.145 psi.

2. Device is ratiometric within this specified excitation range.

3. Offset (V_{off}) is defined as the output voltage at the minimum rated pressure.

4. Full Scale Output (V_{FSO}) is defined as the output voltage at the maximum or full rated pressure.

5. Full Scale Span (V_{FSS}) is defined as the algebraic difference between the output voltage at full rated pressure and the output voltage at the minimum rated pressure.

6. Accuracy (error budget) consists of the following:

Linearity: Output deviation from a straight line relationship with pressure over the specified pressure range.

Temperature Hysteresis: Output deviation at any temperature within the operating temperature range, after the temperature is cycled to and from the minimum or maximum operating temperature points, with zero differential pressure applied.

Pressure Hysteresis: Output deviation at any pressure within the specified range, when this pressure is cycled to and from the minimum or maximum rated pressure, at 25°C .

TcSpan: Output deviation over the temperature range of 10° to 60°C , relative to 25°C .

TcOffset: Output deviation with minimum rated pressure applied, over the temperature range of 10° to 60°C , relative to 25°C .

Variation from Nominal: The variation from nominal values, for Offset or Full Scale Span, as a percent of V_{FSS} , at 25°C .

7. Auto Zero at Factory Installation: Due to the sensitivity of the MPXV7002 Series, external mechanical stresses and mounting position can affect the zero pressure output reading. Auto zero is defined as storing the zero pressure output reading and subtracting this from the device's output during normal operations. Reference AN1636 for specific information. The specified accuracy assumes a maximum temperature change of $\pm 5^\circ\text{C}$ between auto zero and measurement.

8. Response Time is defined as the time for the incremental change in the output to go from 10% to 90% of its final value when subjected to a specified step change in pressure.

9. Warm-up Time is defined as the time required for the product to meet the specified output voltage after the Pressure has been stabilized.

تهیه و توزیع قطعات الکترونیک

2 Maximum Ratings

Table 2. Maximum Ratings⁽¹⁾

Rating	Symbol	Value	Unit
Maximum Pressure ($P_1 > P_2$)	P_{max}	75	kPa
Storage Temperature	T_{stg}	-30 to +100	°C
Operating Temperature	T_A	10 to 60	°C

1. Exposure beyond the specified limits may cause permanent damage or degradation to the device.

Figure 1 shows a block diagram of the internal circuitry integrated on a pressure sensor chip.

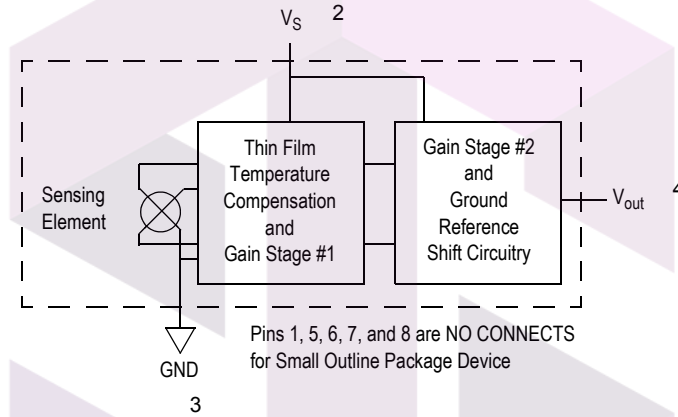

Figure 1. Integrated Pressure Sensor Schematic

SKYTECH

تهیه و توزیع قطعات الکترونیک

3 On-Chip Temperature Compensation, Calibration and Signal Conditioning

The performance over temperature is achieved by integrating the shear-stress strain gauge, temperature compensation, calibration and signal conditioning circuitry onto a single monolithic chip.

Figure 2 illustrates the Differential or Gauge configuration in the basic chip carrier (Case 482). A gel die coat isolates the die surface and wire bonds from the environment, while allowing the pressure signal to be transmitted to the sensor diaphragm.

The MPXV7002 series pressure sensor operating characteristics, and internal reliability and qualification tests are based on use of dry air as the pressure media. Media, other than dry air, may have adverse effects on sensor performance and long-term reliability. Contact the factory for information regarding media compatibility in your application.

Figure 3 shows the recommended decoupling circuit for interfacing the integrated sensor to the A/D input of a microprocessor or microcontroller. Proper decoupling of the power supply is recommended.

Figure 4 shows the sensor output signal relative to pressure input. Typical, minimum, and maximum output curves are shown for operation over a temperature range of 10° to 60°C using the decoupling circuit shown in Figure 3. The output will saturate outside of the specified pressure range.

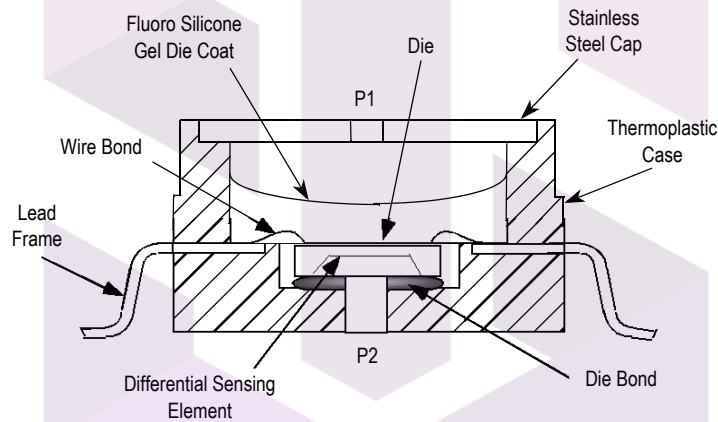

Figure 2. Cross-Sectional Diagram SOP (not to scale)

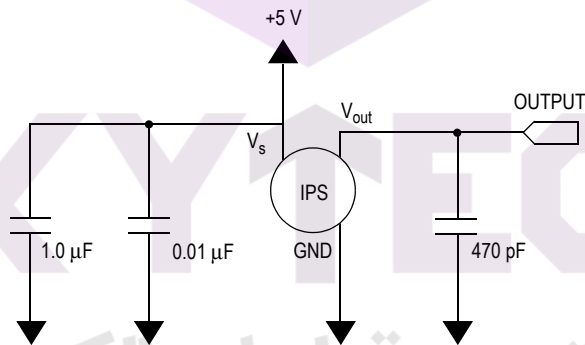

Figure 3. Recommended Power Supply Decoupling and Output Filtering (For additional output filtering, please refer to Application Note AN1646.)

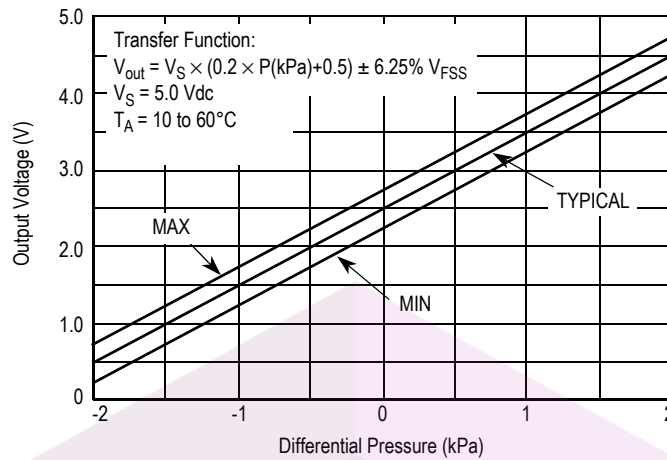

Figure 4. Output versus Pressure Differential

4 Pressure (P1)/Vacuum (P2) Side Identification Table

NXP designates the two sides of the pressure sensor as the Pressure (P1) side and the Vacuum (P2) side. The Pressure (P1) side is the side containing a gel die coat which protects the die from harsh media.

The Pressure (P1) side may be identified by using the following table:

Part Number	Case Type	Pressure (P1) Side Identifier
MPXV7002GC6U/GC6T1	482A-01	Side with Port Attached
MPXV7002GP	1369-01	Side with Port Attached
MPXV7002DP	1351-01	Side with Part Marking

5 Minimum Recommended Footprint for Surface Mounted Applications

Surface mount board layout is a critical portion of the total design. The footprint for the surface mount packages must be the correct size to ensure proper solder connection interface between the board and the package. With the correct footprint, the packages will self align when subjected to a solder reflow process. It is always recommended to design boards with a solder mask layer to avoid bridging and shorting between solder pads.

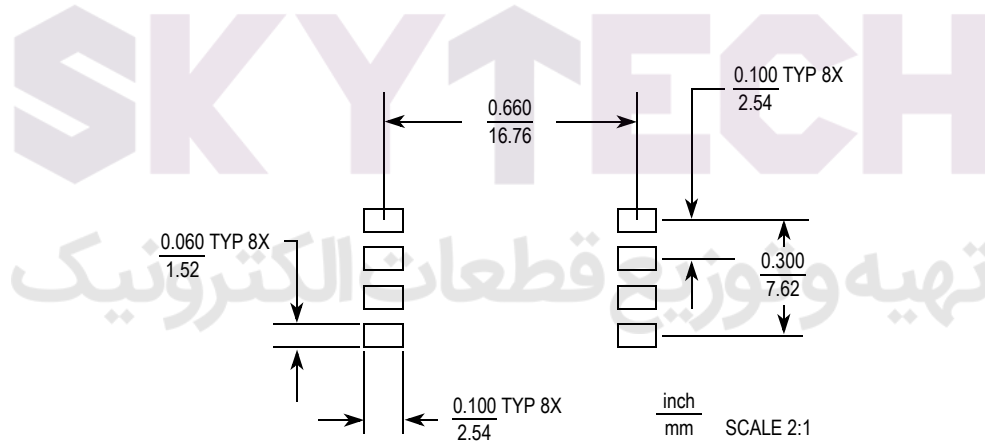
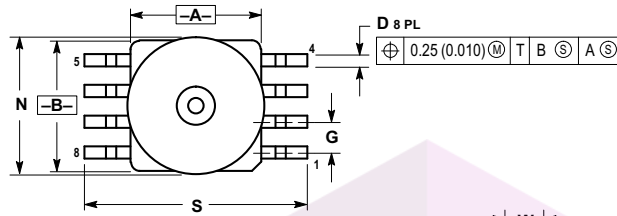

Figure 5. Small Outline Package Footprint

6 Package Dimensions



D 8 PL
 $\oplus 0.25 (0.010) \text{ (M) T B (S) A (S)}$

- NOTES:
1. DIMENSIONING AND TOLERANCING PER ANSI Y14.5M, 1982.
 2. CONTROLLING DIMENSION: INCH.
 3. DIMENSION A AND B DO NOT INCLUDE MOLD PROTRUSION.
 4. MAXIMUM MOLD PROTRUSION 0.15 (0.006).
 5. ALL VERTICAL SURFACES 5° TYPICAL DRAFT.

DIM	INCHES		MILLIMETERS	
	MIN	MAX	MIN	MAX
A	0.415	0.425	10.54	10.79
B	0.415	0.425	10.54	10.79
C	0.500	0.520	12.70	13.21
D	0.038	0.042	0.96	1.07
G	0.100 BSC		2.54 BSC	
H	0.002	0.010	0.05	0.25
J	0.009	0.011	0.23	0.28
K	0.061	0.071	1.55	1.80
M	0°	7°	0°	7°
N	0.444	0.448	11.28	11.38
S	0.709	0.725	18.01	18.41
V	0.245	0.255	6.22	6.48
W	0.115	0.125	2.92	3.17

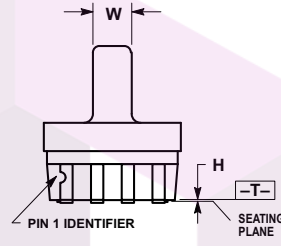
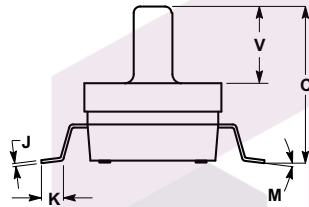

CASE 482A-01
 ISSUE A

DATE 05/13/98

CASE 482A-01
 ISSUE A
 SMALL OUTLINE PACKAGE

SKYTECH

تهیه و توزیع قطعات الکترونیک

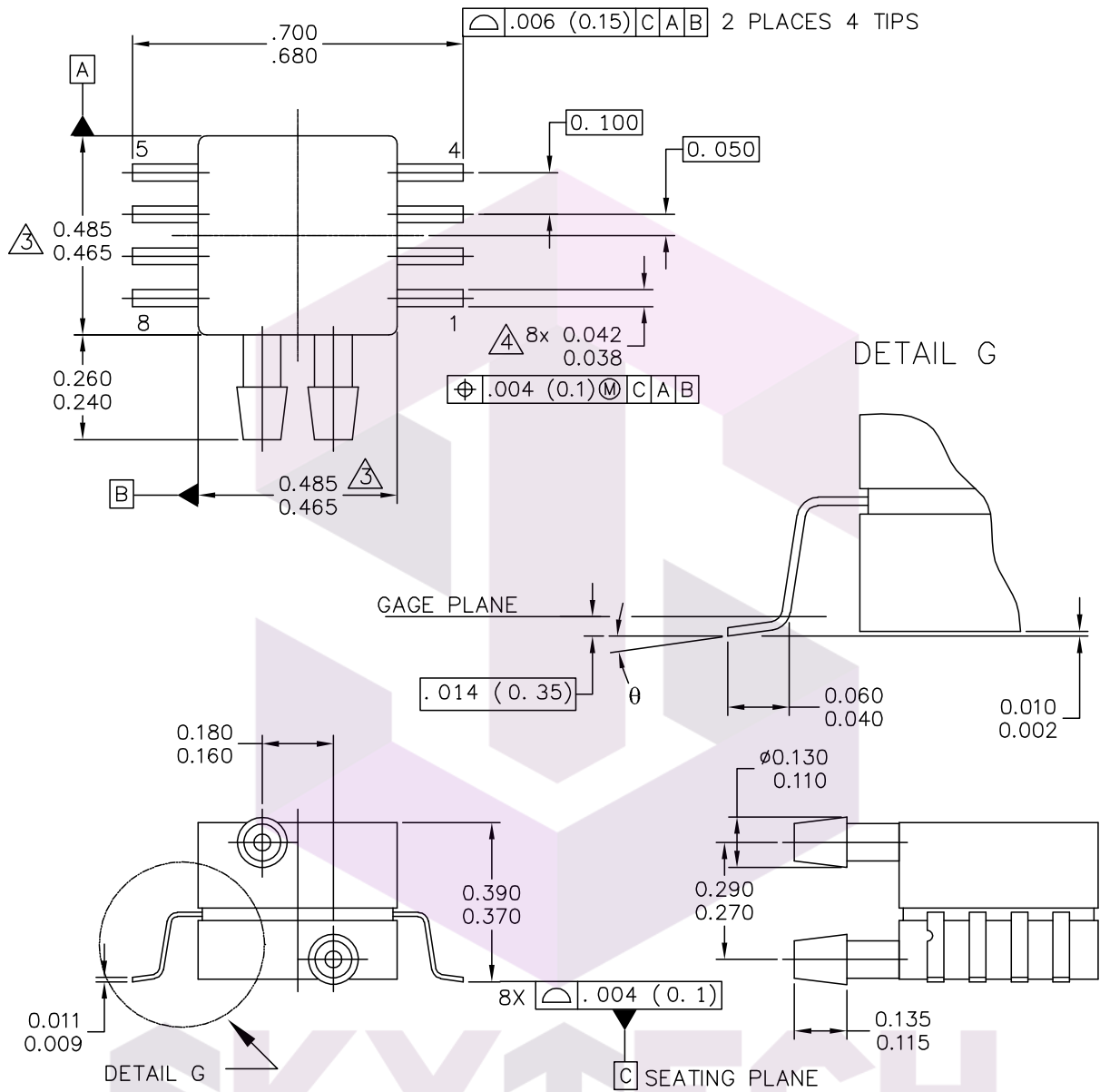

© NXP SEMICONDUCTORS N. V. ALL RIGHTS RESERVED	MECHANICAL OUTLINE	PRINT VERSION NOT TO SCALE
TITLE: 8 LD SNSR, DUAL PORT	DOCUMENT NO: 98ASA99255D	REV: B
	STANDARD: NON-JEDEC	
	SOT1693-1	14 MAR 2016

**CASE 1351-01
ISSUE A
SMALL OUTLINE PACKAGE**



NOTES:

1. CONTROLLING DIMENSION: INCH
2. INTERPRET DIMENSIONS AND TOLERANCES PER ASME Y14.5M-1994.

3. DIMENSIONS DO NOT INCLUDE MOLD FLASH OR PROTRUSIONS.
MOLD FLASH AND PROTRUSIONS SHALL NOT EXCEED .006 PER SIDE.

4. DIMENSION DOES NOT INCLUDE DAMBAR PROTRUSION. ALLOWABLE DAMBAR
PROTRUSION SHALL BE .008 MAXIMUM.

STYLE 1:

PIN 1: GND
PIN 2: +Vout
PIN 3: Vs
PIN 4: -Vout
PIN 5: N/C
PIN 6: N/C
PIN 7: N/C
PIN 8: N/C

STYLE 2:

PIN 1: N/C
PIN 2: Vs
PIN 3: GND
PIN 4: Vout
PIN 5: N/C
PIN 6: N/C
PIN 7: N/C
PIN 8: N/C

SKYTECH

© NXP SEMICONDUCTORS N. V. ALL RIGHTS RESERVED	MECHANICAL OUTLINE	PRINT VERSION NOT TO SCALE
TITLE: 8 LD. SNSR, DUAL PORT	DOCUMENT NO: 98ASA99255D	REV: B
	STANDARD: NON-JEDEC	
	SOT1693-1	14 MAR 2016

**CASE 1351-01
ISSUE A
SMALL OUTLINE PACKAGE**

MPXV7002



NOTES:

1. CONTROLLING DIMENSION: INCH
2. INTERPRET DIMENSIONS AND TOLERANCES PER ASME Y14.5M-1994.
3. DIMENSIONS DO NOT INCLUDE MOLD FLASH OR PROTRUSIONS.
MOLD FLASH AND PROTRUSIONS SHALL NOT EXCEED .006 (0.152) PER SIDE.
4. DIMENSION DOES NOT INCLUDE DAMBAR PROTRUSION. ALLOWABLE DAMBAR PROTRUSION SHALL BE .008 (0.203) MAXIMUM.

DIM	INCHES		MILLIMETERS		DIM	INCHES		MILLIMETERS	
	MIN	MAX	MIN	MAX		MIN	MAX	MIN	MAX
A	.300	.330	7.62	8.38	θ	0°	7°	0°	7°
A1	.002	.010	0.05	0.25	---	---	---	---	---
b	.038	.042	0.96	1.07	---	---	---	---	---
D	.465	.485	11.81	12.32	---	---	---	---	---
E	.717 BSC		18.21 BSC		---	---	---	---	---
E1	.465	.485	11.81	12.32	---	---	---	---	---
e	.100 BSC		2.54 BSC		---	---	---	---	---
F	.245	.255	6.22	6.47	---	---	---	---	---
K	.120	.130	3.05	3.30	---	---	---	---	---
L	.061	.071	1.55	1.80	---	---	---	---	---
M	.270	.290	6.86	7.36	---	---	---	---	---
N	.080	.090	2.03	2.28	---	---	---	---	---
P	.009	.011	0.23	0.28	---	---	---	---	---
T	.115	.125	2.92	3.17	---	---	---	---	---
© NXP SEMICONDUCTORS N. V. ALL RIGHTS RESERVED			MECHANICAL OUTLINE			PRINT VERSION NOT TO SCALE			
TITLE: 8 LD SOP, SIDE PORT					DOCUMENT NO: 98ASA99303D REV: E				
					STANDARD: NON-JEDEC				
					SOT1693-3		14 MAR 2016		

**CASE 1369-01
ISSUE B
SMALL OUTLINE PACKAGE**

7 Revision History

Table 1. Revision History

Document ID	Release Date	Data sheet status	Change notice	Supersedes
MPXV7002 Rev. 4	2017 March	Technical data	—	MPXV7002 Rev. 3.0
Modifications	<ul style="list-style-type: none">• Added MPXV7002DPT1 to the Ordering Information table on page 1.• Updated Pressure offset min, typ, max values from 2.25, 2.5 and 2.75 to 0.25, 0.5 and 0.75 respectively in Table 1 on page 3.• The format of this data sheet has been redesigned to comply with current identity guidelines of NXP Semiconductors. Legal texts have been adapted to the new company name where appropriate.• Updated package outlines 98ASA99303D and 98ASA99255D in Section 6, "Package Dimensions" to comply with current identity guidelines of NXP Semiconductors.			
MPXV7002 Rev. 3.0	2015 January	Technical data	—	MPXV7002 Rev. 2.0
MPXV7002 Rev. 2.0	2009 January	Technical data	—	MPXV7002 Rev. 1.0
MPXV7002 Rev. 1.0	2008 September	Technical data	—	MPXV7002 Rev. 0
MPXV7002 Rev. 0	2005 September	Technical data	—	—



How to Reach Us:

Home Page:

[NXP.com](http://www.nxp.com)

Web Support:

<http://www.nxp.com/support>

Information in this document is provided solely to enable system and software implementers to use NXP products. There are no expressed or implied copyright licenses granted hereunder to design or fabricate any integrated circuits based on the information in this document. NXP reserves the right to make changes without further notice to any products herein.

NXP makes no warranty, representation, or guarantee regarding the suitability of its products for any particular purpose, nor does NXP assume any liability arising out of the application or use of any product or circuit, and specifically disclaims any and all liability, including without limitation, consequential or incidental damages. "Typical" parameters that may be provided in NXP data sheets and/or specifications can and do vary in different applications, and actual performance may vary over time. All operating parameters, including "typicals," must be validated for each customer application by the customer's technical experts. NXP does not convey any license under its patent rights nor the rights of others. NXP sells products pursuant to standard terms and conditions of sale, which can be found at the following address:

<http://www.nxp.com/terms-of-use.html>.

NXP, the NXP logo, Freescale, the Freescale logo, and the Energy Efficient Solutions logo are trademarks of NXP B.V. All other product or service names are the property of their respective owners. All rights reserved.

© NXP B.V. 2017. All rights reserved.

SKYTECH

تهيئه وتوزيع قطعات الكترونيك